

VISOR® V10 Allround Color

Allround vision sensor for complex inspection tasks, 6 mm



PRODUCT HIGHLIGHTS

- All evaluations ("Detectors") of object sensor and code reader united in one device
- Real-world engineering units and robot coordinates at a mouse click
- Precise position determination: X/Y-position and orientation
- Can be used for all common 2D-Codes (ECC 200-Data-matrix) and common 1D-bar codes
- User-friendly configuration and viewer software with graded user rights and online help

Optical data		Functions	
Resolution	736 x 480 pixels	Number of jobs / detectors	max. 255 / max. 255
CMOS	1/3", colour	Detectors ¹	Contour, pattern comparison, calliper, BLOB, contrast, brightness, grey level, data code, bar code, OCR, colour list, colour area, colour value
Integrated lens, focal length	6 mm, adjustable focal position	Properties	Position tracking: X/Y and orientation; pattern comparison / contour: teach-in and detection of patterns and contours; calliper: distance between edges; BLOB; grey threshold, brightness: evaluation of brightness; contrast: evaluation of contrast; colour value: output of colour values; colour area: two-dimensional colour inspection with adjustable tolerance; colour list: detecting the most similar colours; bar code: reading 1D bar codes, EAN, UPC, RSS, 2/5 Interleaved, 2/5 Industrial, code 32, code 39, code 93, code 128, GS1, pharm code, codabar; data code: reading 2D codes: ECC200, QR code, PDF 417; OCR
Adjustment range	6 mm to infinity	Typical cycle times	Typ. 20 ms pattern comparison; typ. 30 ms contour; typ. 8 ms calliper; typ. 30 ms BLOB; typ. 2 ms brightness; typ. 2 ms contrast; typ. 2 ms grey threshold; typ. 2 ms colour value; typ. 30 ms colour area; typ. 2 ms colour list; typ. 30 ms bar code; typ. 40 ms data code; typ. 15 ms per character OCR
Integrated illumination	White LEDs		
Minimum field of view, X x Y	5 x 4 mm ²		
Electrical data		Mechanical data	
Operating voltage, +U _B	18 ... 26.4V DC ¹	Dimensions	65 x 45 x 45 mm (without plug)
Current consumption (without illumination and I/O)	≤ 120 mA	Enclosure rating	IP 67
Current consumption (without I/O)	≤ 200 mA	Material, housing	Aluminium, plastic
Protective circuits	Reverse-polarity protection, U _B / short-circuit protection of all outputs	Material, front screen	Plastic
Power On Delay	Ca. 13 s after Power on	Ambient temperature: operation	0 ... +50 °C ²
Outputs	PNP / NPN (switchable)	Ambient temperature: storage	-20 ... +60 °C ²
Max. output current (per output)	50 mA, 100 mA (pin 12)	Weight	Ca. 160 g
Inputs	PNP/NPN High > U _B -1V, Low < 3V	Plug connections	Supply and I/O M12, 12-pin Ethernet M12, 4-pin Data M12, 5-pin
Input resistance	> 20 kOhm	Vibration and impact resistance	EN 60947-5-2
Encoder input	High > 4V		
Interfaces	Ethernet (LAN), RS422, RS232, EtherNet/IP, PROFINET, SensoWeb		
Inputs/outputs	2 inputs, 4 outputs, 4 selectable inputs/outputs		

¹ Max. ripple < 5V_{SS} ² 80 % air humidity, non-condensing

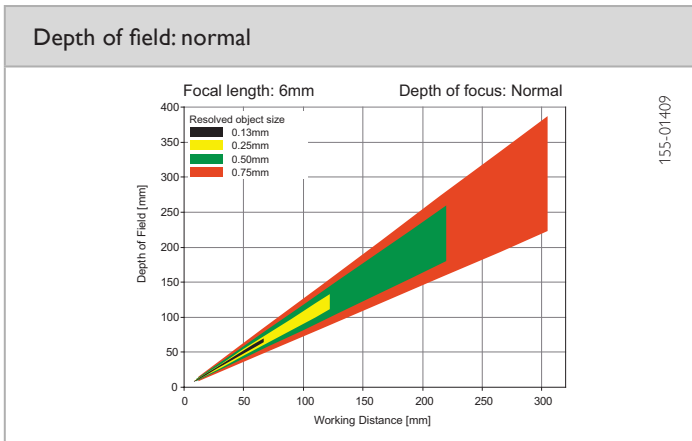
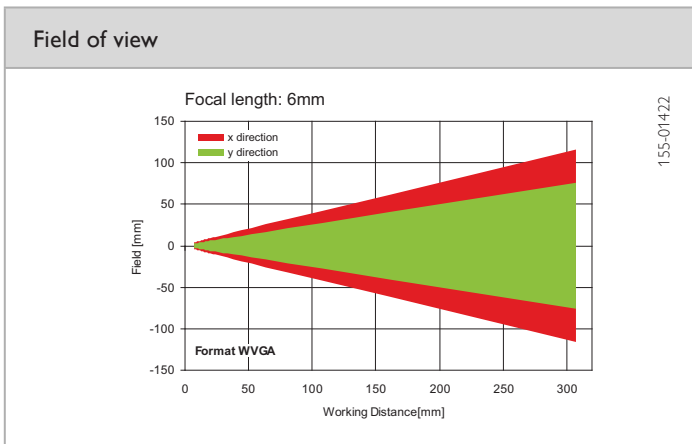
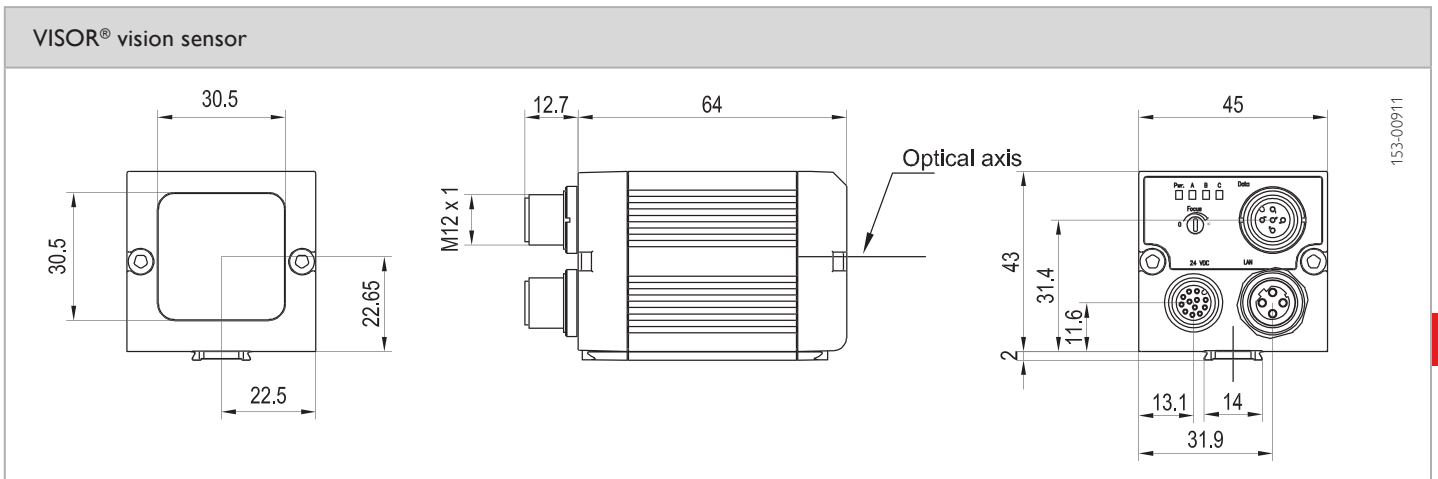

Illumination	Part number	Article number
White	V10C-ALL-A2-W6	535-91102

Accessories	
Connection cables	From Page A-38
Illumination	From Page A-30
Brackets	From Page A-14
Interface accessories	From Page A-42